

FUJIFILM

OFFICIAL IMAGING SPONSOR
OF WORLD CUP FRANCE 98



New

Digital Camera
FUJIFILM DX-5



When you keep the DX-5 in a pocket, you'll be amazed at how handy it is (and how much fun digital snapshotting can be). Along with the quality of a 350,000-pixel CCD, you'll have the convenience of unlimited storage. When you think about the pricing too, there's only one conclusion. The Digital Age has been trimmed down to size, and it fits perfectly now.



All the Right Moves

Make Every Moment Count

You might be a business professional who needs high-quality images for meetings or presentations that won't wait. Maybe you're a student who would like to e-mail snapshots to friends and relatives back home. Or perhaps you're new parents who want to save years of smiles in a digital photo album.

Whatever you need and wherever you go, the DX-5 makes it simple. You'll like the quality of the 350,000-pixel CCD, the pocket-size dimensions and the affordable price. You'll also find the DX-5 is as friendly as an ordinary compact camera. And since it uses an incredibly small SmartMedia™ Card for removable storage, there's no limit on how many images you can shoot. To input images to your home computer, just use the included serial cable and software.

However you look at it, the DX-5 is the anywhere-anytime digital camera. And it's the easy way to make every moment count.

IMAGE QUALITY

Quality Time

The DX-5 has the high resolution of a 350,000-pixel CCD in an array of 640 × 480 pixels. To prevent any distortion, its square pixels have been designed specially for a digital camera, and the RGB filter ensures exceptionally accurate color reproduction. The result is all you've been looking for—truer colors and less "noise" in the luminosity. And this quality will be just as clear when you use a digital printer for output.



performance in professional broadcast cameras.

Sharp Ideas

The DX-5's sharp Fujinon lens offers wide-angle coverage equivalent to that of a conventional compact camera's 38 mm lens. And you can be sure the quality is absolutely uncompromising since the design has won quite a reputation for its

EASY CONNECTIVITY

The New Standard

The DX-5 stores images on a removable SmartMedia™ Card. Even though it's only the size of a postage stamp (and just 0.76 mm thick), a 2MB card can hold up to 30 images in the Normal Mode and 22 images in the Fine Mode. Keep an extra one at hand, and you'll always have room for another shot.



Very Well Adapted

The adapter for the SmartMedia™ Card makes PC input as simple as you could want. Just use the optional PC Card Adapter to insert the SmartMedia™ Card in a PC Card slot.



Digital Camera FUJIFILM DX-5



Actual size

The slanted photos on these pages were taken with the DX-5.



Communication Port, Too

The DX-5 has a serial port, so you can use the included RS-232C cable to connect the camera directly to your PC.

The Fun Factor

After you've captured the images and input them to the PC, use the included PhotoEnhancer™ software to modify them in countless ways. It's so friendly and easy that it adds to the fun.

CONVENIENT HANDLING

Trim Good Looks

The DX-5 measures just 112 (W) × 66 (H) × 40 (D) mm, and it weighs only 160 g without batteries. Ultracompact and lightweight, it will fit in your pocket so you'll always be ready for digital snapshotting.

Power to Spare

The DX-5 is so energy-efficient that you can use the included alkaline AA batteries to shoot 250 images* (employing the flash half the time). Since AA batteries

are widely available, you'll never be at a loss. You can also use a long-life lithium or nickel-cadmium battery, and an optional AC Adapter is available.

*The actual number of shots depends on the type of alkaline batteries used.

In a Flash

The Built-in Flash is ready for dim or difficult lighting. To give you the right answer in every situation, there are four Flash Modes, including Red-Eye Reduction.



Creativity Comes Naturally

The Optical Viewfinder makes composing as natural and convenient as it is with a 35 mm camera. Showing all the information you need, the LCD Panel also gives you complete control.



SPECIFICATIONS

DIGITAL CAMERA FUJIFILM DX-5

CCD sensor	1/3-inch CCD with 350,000 square pixels	Shutter speeds	1/4~1/5,000 sec.									
Resolution	640 × 480 pixels	Viewfinder	Reverse Galilean optical viewfinder									
File format	JPEG (Exif)	Flash	Built-in Auto Flash with 3.6 m/12 ft. range									
Storage media	SmartMedia™ Card (3.3V and 5V)	Output	Digital: Mini DIN (9 pin) for serial interface									
Number of images	<table border="1"> <tr> <td>Mode</td> <td>2MB</td> <td>4MB</td> </tr> <tr> <td>Normal</td> <td>30</td> <td>60</td> </tr> <tr> <td>Fine</td> <td>22</td> <td>44</td> </tr> </table>	Mode	2MB	4MB	Normal	30	60	Fine	22	44	Power source	2 AA batteries, AC power adapter
Mode	2MB	4MB										
Normal	30	60										
Fine	22	44										
Lens focal length	f = 5.7 mm (equivalent to 38 mm with a 35 mm camera)	Dimensions	112 (W) × 66 (H) × 40 (D) mm/ 4.4 (W) × 2.6 (H) × 1.6 (D) in.									
Lens/Aperture	TV-Fujinon lens with 2 steps (F3.1/F8)	Weight	Approx. 160 g/5.6 oz. excluding batteries, strap and SmartMedia™ Card									
Focus distance	70 cm/28 in. to infinity	Included accessories	<ul style="list-style-type: none"> • 2MB SmartMedia™ Card • 2 AA alkaline batteries • Serial cables for Windows® and Macintosh® • CD-ROMs (interface software and PhotoEnhancer™) for Windows® and Macintosh® • Hand strap 									
Sensitivity	Equivalent to ISO 150 (ISO 200 with flash)											
Exposure control	TTL Aperture-Priority AE											
White balance	5500K fixed											

Specifications are subject to change without notice.

OPTIONAL ACCESSORIES



SmartMedia™ Cards
MG-2 (2MB)
MG-4 (4MB)



AC Power Adapter
AC-3V



PC Card Adapter
PC-AD



Battery Charger with Battery
BK-68PF



Soft Case
SC-DX5

SYSTEM CONFIGURATION

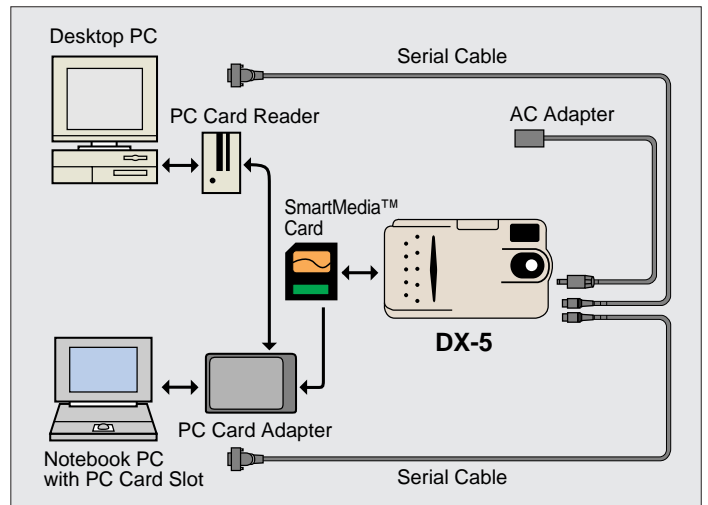

Macintosh® is a registered trademark of Apple Computer, Inc.
Windows® is a registered trademark of Microsoft Corporation.
All other trademarks are the property of their respective holders.